



XDi Series

HIGH PERFORMANCE COMPONENT SPEAKERS

XDi 5.2 XDi 6.2

INSTALLATION MANUAL

INTRODUCTION

Thank you for choosing ARC Audio's ***XDi SERIES*** hi-performance mobile audio products. We hope you enjoy your experience with all our products and we welcome any questions or comments you may have.

SPECIFICATIONS

<i>XDi 5.2</i>		<i>XDi 6.2</i>	
Diameter	5 ¼"	Diameter	6 ½"
Musical Power	160 watts	Musical Power	240 watts
Nor. Power	80 watts	Nor. Power	120 watts
Sensitivity	86dB	Sensitivity	98dB
Frequency response	65hz- 20Khz	Frequency response	55hz- 20Khz
IMP.	4 Ohm	IMP.	4 Ohm
Cut Out Diameter	4 5/8"	Cut Out Diameter	5 5/8"
Mounting Depth	2"	Mounting Depth	2 ½"

A WORD ON DISTORTION

Most speaker damage occurs as a result of amplifier distortion also known as "Clipping". Clipping occurs when an amp is driven beyond its maximum rated output. This kind of distortion can be hard to hear unless you know what to listen for. Any time you hear a harsh ear piercing sound at hi volume your amp is probably clipping.

CAUTION:

Please check the suitability of the installation location before you begin. Do not cut any of the car's structure. Pay attention to the mechanism of the window and door.

If you do not have experience with automotive electrical and mechanical systems contact a professional installer. Paying a qualified installer is almost always cheaper than paying a dealership to repair your car.

THE INSTALL

After you have found the best location for the woofer, make or enlarge the mounting hole. Make sure the opening is just large enough for the woofer to fit tightly with no gaps. Make sure the surface is flat and that the speaker does not bind up in the opening. Use an awl or felt pen to mark the panel and drill the screw holes without the speaker in place. This will save the costly mistake of punching a hole in one of your new speakers. Install the woofer with the grill ring using the 4 screws provided with this system. Firmly seat the grill into its ring.

Remove the grill from the trim ring first then follow the steps below installation.

1. Place the speaker in the opening with the trim ring over it.
2. Screw the trim ring through the panel with the clips beneath.
3. Install the grill into the trim ring. Add a few drops of glue if necessary.
4. Snap in the finish ring.

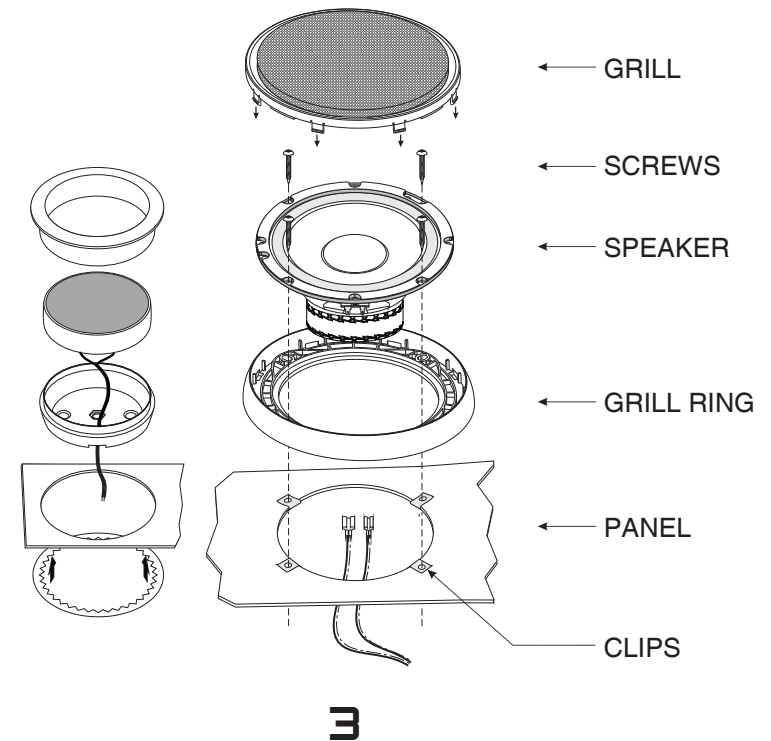

2

3

Install the Tweeter

The tweeter comes with 2 different types of mounts. Flush mount and Surface mount.

Flush Mount

Cut a hole in the panel you wish to install in. Assemble the tweeter in the mount. Make sure the hole is large enough for the tweeter and install it through the hole. Firmly install the retainer to the back of the tweeter. Reinstall the panel and point the tweeter at a location between the driver and passenger at ear level.

Surface Mount

Hold the back piece for the mount in place and mark the screw locations. Pre drill the screw holes and the hole for the wire. Screw the mount to the panel tightly. Run the wire through the hole and gently pull it until the tweeter is fully seated in the mount. Install the retainer and point the tweeter.

Crossovers

Install the Crossover in a dry location and secure it firmly. Don't just drop it in the bottom of the door.

Wiring

When wiring this system it is important to make all connections carefully and securely. Follow the instructions carefully. All audio connections have a + and -. If one is wired backward the system will play but will sound strange. One speaker will play Out of Phase (backwards) from the others. You may notice a loss of bass response and the vocals will not be in the center of the sound field.

Connect the Woofer

Using the wire provided with the system connect the positive and negative to the woofer. Run these wires to the crossover and connect them to the terminals marked Woofer + and -.

Connect the Tweeter

Connect the positive and negative to the amplifier output. Run these wires to the crossover and connect them to the terminals marked Tweeter +and-.

Connect the Amp

Connect the positive and negative to the amplifier output. Run these wires to the crossover and connect them to the terminals marked Input +and-.

ARC AUDIO WARRANTY AND SERVICE GUIDELINES

Note to International Customers-

For warranty and repair service outside of the USA, please send your product directly to your countries authorized Arc Audio distributor for your service needs. As a customer you do have the option to send your product directly back to the factory in the USA but you will be responsible for "ALL" shipping costs, taxes, and duties to and from the USA. Return shipping charges and fee's must be paid by Credit Card with a signed credit card authorization form prior to the return shipment. This includes shipping cost, customs fee's, duties, local and government import/export tax's, broker's fee's and any other misc. fee's that could be added by your local government or other international agencies. International warranty shipments will not be accepted without a proper return authorization number and/or sales receipt documentation.

ARC AUDIO warrants all new products against defects in material and workmanship for a period of ONE (1) YEAR from the original date of purchase from an AUTHORIZED ARC AUDIO RETAILER. This warranty is not transferable and applies only to the original retail purchaser of the product from an authorized ARC AUDIO retailer. Upon inspection by ARC AUDIO should services be necessary under this warranty for any reason due to manufacture defects ARC AUDIO will, at its sole discretion, repair or replace the defective product with new or similar conditioned product at no charge.

THIS WARRANTY DOES NOT COVER INSTALLATION OR DAMAGE RESULTING FROM ACCIDENT, MISUSE, ABUSE, IMPROPER WIRING, OPERATION OUTSIDE OF UNIT OUTSIDE OF MANUFACTURES SPECIFICATIONS, OR AGAINST INSTRUCTIONS IN OWNERS MANUAL. IN ADDITION ANY PRODUCT THAT HAS BEN OPENED, TEMPERED WITH OR MODIFIED, OR IF ANY SERIAL NUMBERS HAVE BEEN REMOVED OR ALTERED WILL NOT BE COVERED BY ANY PART OF THE MANUFACTURES WARRANTY.

All warranty returns should be sent to ARC AUDIO freight prepaid and must be accompanied by proof of purchase (a copy of the original sales receipt). Direct returns from consumers or non-authorized retailers will be refused unless specifically authorized by ARC AUDIO with a valid return authorization number.

All warranty returns must be packed in original packaging and be accompanied by a copy of the original printed sales receipt. Product damaged in shipment due to improper packaging will not be covered under this warranty and the customer or retailer will be charged full cost to repair the specific piece of product back to a like new or similar condition.

In no event will ARC AUDIO be liable for incidental, consequential, or other damages resulting from the use of this product, this includes but is not limited to, damage of hearing, property or person, damage based upon inconvenience or on loss of use of the product, and to the extent permitted by law, damages for personal injury. This warranty gives you specific legal rights, and you may have other rights, which vary from state to state. This warranty applies to products sold and used in the United States of America. In all other countries please contact your distributor.

The following are examples of what is not covered under Arc Audio's warranty policy-

- Any Product that is missing or has altered/damaged Serial numbers
- Any Product that has been damaged as a result of physical abuse
- Any Product that has been modified or altered from its original form or design and/or repair has been attempted by unauthorized repair facilities.
- Any product that has been previously owned by another use and was sold private party. (Arc Audio's warranty policy is not transferable to third party or second hand users)
- Any product purchased from ANY form of online marketplace (web sites, EBay or similar auction site, web site talk forum sales, etc)
- Any product not purchased at a brick and mortar authorized store front location.
- Any Speaker or Subwoofer than has been damaged to over-powering causing burnt voice coils and/or mechanical failures such as ripped spiders or surrounds.
- Product that has not been installed as per manufacture recommendations including wiring and installation related damage to product.
- Cosmetic damage due to installation, shipping and handling, and normal wear and tear.
- Arc Audio will not be responsible for any product that has any kind of custom finish or customized cosmetic additions that differs from the original form as manufacture from Arc Audio.
- Products damaged by "Acts of God" (Flood, Fire, Infestations, etc.)

A Few Do's and Don'ts

- Always use the crossovers. To leave the crossover out will result in almost certain damage to the component speakers.
- Care must be taken not to mix the tweeter and woofer connections. The system will not work and may be damaged.
- Do not add more speakers to the crossover. The crossover is designed for the speakers provided only.

If you have any Question about this product please call
ARC Audio Technical Service:

209-543-8706