



KS 900.6

HIGH PERFORMANCE AUDIO AMPLIFIER



Introduction	2
Finding a Suitable Location	2
Supplying Power	3
The Ground	3
Running the Cables	3
Setting the Gains	3
Controls and Features	
Inputs	4
Center Channel Input	4
Mode Switch	4
Bridged Input	5
Crossovers	5
Bass Boost	5
Speaker Outputs	5
Installation Instructions	6
Diagnostic Fault Codes	7
Controls	8
Specifications	8
Source Select Switches	9
System Diagrams	
4 Channel Stereo W/Bridged Subwoofer	10
4 Channel Stereo W/Mono Subwoofers	11
5 Channel Stereo W/Bridged Subwoofer	12
6 channel Stereo	13
2 Channel Bridged W Bridged Sub (3 CH)	14
Power Wiring	14
Warranty	15

Congratulations!

Thank you for purchasing an ARC Audio Hi-Performance Amplifier.

ARC Audio amplifiers are conservatively rated and produce more power per channel than others in their class. Manufactured to the highest standards of quality and reliability to deliver years of listening enjoyment.

ARC Audio...**SOLID CONSTRUCTION for SOUND Car Audio Systems.**

Warning

We build all ARC Audio products to play at high volumes for extended periods of time. Your ears however are not designed for high volume listening. This product can easily generate volumes that can permanently damage your hearing. We urge you to limit your exposure to very high volume sound.

You may also find your state has laws governing the volume of an audio system in a car. Please be aware of all local and state laws in your area.

A properly tuned and operated audio system will deliver years of enjoyment when used properly.

Installation Instructions

ARC Audio KAR Series Amplifiers are designed for easy installation in your vehicle. To ensure proper operation of your new purchase, please follow the suggestions we have listed below:

Warning

Please check the suitability of the installation location before you begin. Do not cut any of the car's structure. Pay close attention to what is behind the panels or carpet. Often the manufacturer will hide wires, computers or other electronic devices in the exact areas you wish to install in.

If you do not have experience with automotive electrical and mechanical systems contact a professional installer. Paying a qualified installer is almost always cheaper than paying a dealership to repair your car.

Locating the Amplifier

The amplifiers must be securely mounted to a solid surface. Please select a dry location in the trunk or passenger compartment only. Do not mount the amplifier to any area that may have excess vibration (like the subwoofer box). Position the amplifier in an area that receives sufficient airflow for proper heat dissipation.

Supplying Enough Power

The Laws of Nature

Your amplifier Does NOT make power. It converts power, or current, from your car's electrical system and turns it into a high power musical energy. If the amp can't get all the power it needs it will not produce its full output. Your ARC Audio amplifier will produce Full output for longer than other amps on the market today. If the Voltage or Current drops too low even our amplifiers will drop below their rated output. Make sure your vehicle charging system is in good working order. Any Hi-Performance audio amplifier will increase the demand on your alternator and battery. If you are unsure have your charging system tested by a professional technician.

The Ground!!!

Warning: Read this Carefully

The ground wire should be connected directly to the chassis of your vehicle. Find a clear location close to the amplifier and remove all the paint and sound deadener. Use a #10 or larger screw to secure it. Never use seatbelt bolts for grounding.

Remember, the ground must carry the same high current as the positive power wire.

To reduce the risk of noise, run all signal cables away from any vehicle or power supply wiring.

Running the Cables

Carefully run the power and signal cables through the passenger compartment of the vehicle. Always use a rubber grommet to prevent the power wire from shorting and to reduce the risk of fire. A 4 gauge or larger wire should be used for power and ground connections. We recommend a fuse be installed on the power wire within 18 inches of the battery for safety.

Setting the Gains

So you're worried that your 8 Volt output head unit will be too much for the ARC Audio's 4 Volt input stage.

Don't Be

ARC Audio Amplifiers input stage is rated to 4 volts RMS @ 1KHz without clipping.

Music is very dynamic. Nothing like a 1KHz test tone. It would be rare to see a peak as high as a test tone. Furthermore, your head unit produces its output at full volume but when you tune your system you always set the head unit to 70% of maximum volume.

Input Section

Because of the wide range of head unit output configurations all ARC Audio amplifiers have an adjustable input sensitivity or "Gain". The gain is not a volume or a power limiting control like a throttle. It makes the amp more sensitive to input from the stereo. With the gain up the amp will reach full output at a lower volume setting on the deck. At higher gain settings the amp also becomes more sensitive to noise from the car's electrical system. Try to run the gain at the lowest setting possible for your system.

There is no correct gain setting. Because speakers require different power demands to reach the same output, the gains most often need to be used to compensate for these differences. If you tried to set all the gains at half way you would probably find the system didn't sound very good. Using good judgment and listening carefully to each speaker is still the best way to tune a system.

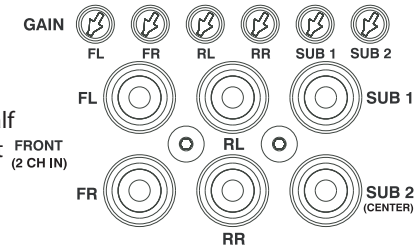

Note: Important New Feature

Center Channel Input

The KS 900.6 is equipped with an optional Center Channel input. This option will change the operation of the Sub 2 output. When the Center Channel switch is pushed in all the controls from the Sub crossover are bypassed and you will be able to use the High Pass controls next to the Center Channel switch.

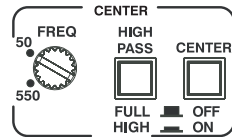

Note: When Center Channel is Off all the Sub controls will effect Sub 1 and Sub 2 equally.

Input Mode Switch

All ARC Audio amplifiers include an input mode switch. This switch controls the signal being sent to the amplifier sections. Most 2 channel amplifiers can be bridged into a single channel however if the signal to the channels is not exactly the same the distortion will increase significantly. The mode switch solves this problem by offering 3 modes of operation.

Stereo

This is simple 2 channel stereo operation. Use this setting for most applications that do not involve bridging the output.

Bridge (R IN)

On this amplifier the Right RCA Front will be sent to the front outputs. The Left Front RCA will be sent to the rear outputs.

This is a great way of get high power to a component set. The amplifier now acts like a 2 channel that makes full power at 4 ohms.

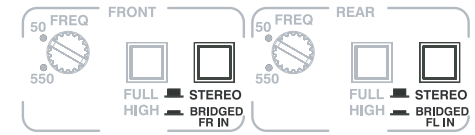

Crossover Controls

A crossover is a device that removes unwanted frequencies from a speaker or amplifier. A tweeter can easily be destroyed by bass notes if they are not filtered out. Likewise a subwoofer will not sound natural if it is playing midrange notes. A crossover removes these sounds from the speaker. As you might guess, careful adjustment is need to ensure that all the speakers are playing the right sounds and that you are left with no "holes" or low spots in the frequency response.

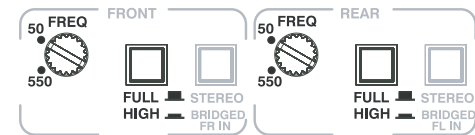

Bass Boost

This amp has an adjustable bass boost on SUB 1 and SUB 2 only. If the CENTER option is being used the BASS BOOST will effect SUB 1 only. Begin your adjustments at low volume. If you do not hear any improvement then the woofer does not need any boost. Use Bass Boost carefully. The demands on power output are tremendous. Try to minimize the use by changing woofer position or the enclosure size.

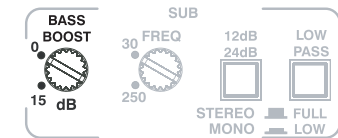

Speaker outputs

This amplifier is a multi channel amplifier design. Meaning it has more than one channel of speaker outputs. It is equipped with a large block style terminal for speaker connection. Make this connection carefully and neatly. Strip your wire back and twist the exposed leads and insert them into the block terminal while being careful that there is no loose or frayed strands of wire and tighten the Phillips head screw down on the terminal till the wire is tightly secured in place. If the wires ever come in contact with each other the amplifier will go into protection.

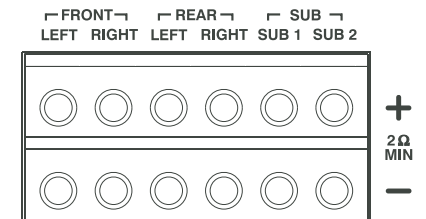

Know your total ohm load before you make any connections.

Installation Instructions

Below is a very abbreviated set of installation instructions. This is not meant as a step by step procedure but is intended to give you a general idea of what is involved and which steps come first. Every installation will be different and may require reordering of these steps. NEVER install the fuse at the battery or connect the negative battery cable until all your connections are final.

Before you start, disconnect the negative cable from any batteries in the car. Tape up the end so it is isolated from the battery.

Run an appropriate gauge wire from the battery to the amplifier. Plan this part of the installation carefully. This cable will carry very high current. If it should short to the body and it is not properly fused it could catch fire. **You DID use a grommet when you ran it through the firewall, didn't you?**

Connect the power wire to the battery using a fuse capable of the total current load of all amplifiers connected. **Don't install the fuse yet.** Wait until the end. Locate the fuse as close as possible to the battery. If the fuse is further than 18 inches (wire length) from the battery, you should reevaluate the wire and fuse placement.

Find the closest clear metal area to the amp for a ground. Sand, grind or scrape all paint and undercoating from the body and screw the ground securely in place. A nut, bolt and lock washer is advisable here.

It is advisable to test the ground with an Ohm meter between the ground cable and the negative battery cable to insure a good low resistance connection. Some alloys used in modern cars do not offer the best ground. If you believe this is the case, consult with the vehicle's manufacturer.

Run the speaker wire to the speakers. It is advised that you leave some extra wire at this point. You can "clean it up" later.

If you haven't already done so, mount the amp now.

Connect the power and ground to the amplifier.

Only after this step should you install the fuse at the battery.

Connect the remote wire from the head unit to the amplifier. Now is a good time to turn on the amp for the first time. Make sure it turns on properly and does not go into protection.

Connect the speaker wires to the amp and speakers (make sure the amp is off first). Make sure the polarity (+ and -) is correct.

Connect the RCA signal wires to the amp.

Double check the amplifier controls at this time. Make sure everything is set correctly for your system.

Now you're ready to play it for the first time. It is best to leave the gain all the way down at first. Start with the head unit volume low and work your way up.

Now you can tune the amp. Take your time and make only one adjustment at a time. It may take some time to get the system fully adjusted. During this time the amp is drawing current from the battery. You should check the battery voltage from time to time and re-charge it if it gets low. That's it. You're done. Now have fun.
ave fun.

This amplifier is equipped with an advanced diagnostic system controlled by the microprocessor. In the event that this unit goes into protection for any reason it will flash the status light found on the control end of the amplifier. The different sequences indicate the "Code" for faster trouble shooting.

BLUE FLASHING

CODE 11 Red Green Flashing

CODE 12 1 Flash, Pause, 2 Flashes

CODE 13 1 Flash, Pause, 3 Flashes

CODE 14 1 Flash, Pause, 4 Flashes

CODE 15 1 Flash, Pause, 5 Flashes

BLUE CODE 12 1 Flash, Pause, 2 Flashes

NORMAL TURN ON

THERMAL PROTECTION (Turn the volume down and wait for the amplifier to cool)

SHORT (Turn the amplifier off and check for a shorted speaker or wire.)

REPEATED SHORT (Correct the short and leave the amp off for 5 minutes.)

OVERVOLT (This is a charging system failure. DO NOT START THE ENGINE.)

DC OFFSET (TURN OFF THE AMPLIFIER. Contact ARC Audio for service.)

PROCESSOR HARD RESET (Amp is OK but the processor reset do to power disconnect.)

INPUT AND CROSSOVER CONTROLS

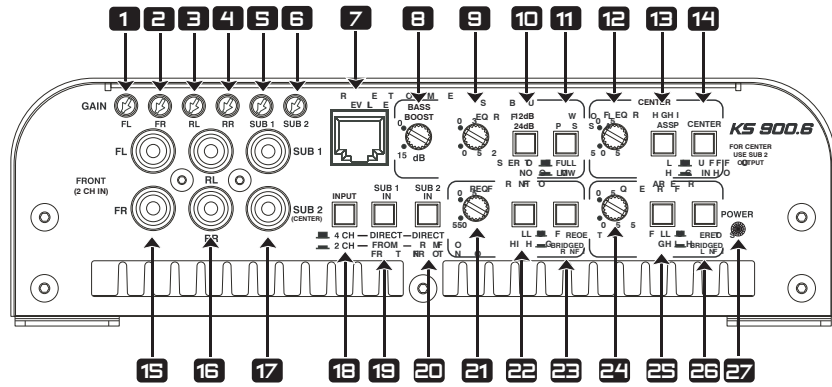

- 1** Front Left Gain
- 2** Front Right Gain
- 3** Rear Left Gain
- 4** Rear Right Gain
- 5** Sub 1 gain
- 6** Sub 2 (Center) Gain
- 7** Remote Level control for Sub 1 and Sub 2
- 8** Bass Boost for Sub 1 and Sub 2
- 9** Sub Crossover Frequency 30Hz to 250Hz
- 10** 12dB/24dB Switch 12dB Stereo 24dB Mono
- 11** Low Pass/Full Range Switch (in for Low Pass)
- 12** Center Channel Frequency 50Hz to 550Hz
- 13** Center High Pass/Full Range Switch (in for High Pass)
- 14** Center On/Off Switch (uses Sub 2 output)
- 15** Front RCA Inputs
- 16** Rear RCA Inputs
- 17** Sub 1 and Sub 2 (Center) Inputs
- 18** Input Source Switch (in Rear uses Front RCA)
- 19** Sub 1 Input Source (in uses Front RCA)
- 20** Sub 2 Input Source (in uses Front RCA)
- 21** Front Channel Frequency 50Hz to 550Hz
- 22** Front High Pass/Full Range Switch (in for High Pass)
- 23** Front Stereo/Bridged Switch (in front gets all input from FR input)
- 24** Rear Channel Frequency 50Hz to 550Hz
- 25** Rear High Pass/Full Range Switch (in for High Pass)
- 26** Rear Stereo/Bridged Switch (in front gets all input from FL input)
- 27** Power/Diagnostic Light

SPECIFICATIONS	KS 900.6
Power output RMS @ 4 ohms	4 X 60 watts
Power output RMS @ 2 ohms	4 X 100 watts
Power output RMS @ 4 ohms (Sub Channels Only)	2 X 155 watts
Power output Bridged @ 4 ohms	2 X 120 watts
Power output Bridged @ 4 ohms (Sub Channels Only)	1 X 550 watts
Transient Distortion (100W)	<.01% @ 4ohms
Frequency Response	20Hz-20KHz
Signal to Noise Ratio	>77dB
Bass Boost	+15dB@45Hz
Crossover (Butterworth)	55Hz-5.5KHz var- 12dB
Fuse	25A X 4
Size	19 1/2" (L) X 8.0" (W) X 2 3/8" (H)

SOURCE SELECT SWITCH OPTIONS

The amplifier is equipped with "SOURCE SELECT" switches. These work like internal "Y" connectors. It is possible to run all six channels with a single pair of RCAs. Below are three of the most common arrangements for these switches

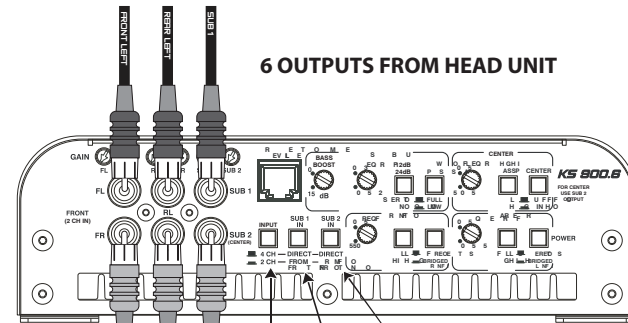

6 OUTPUTS FROM HEAD UNIT

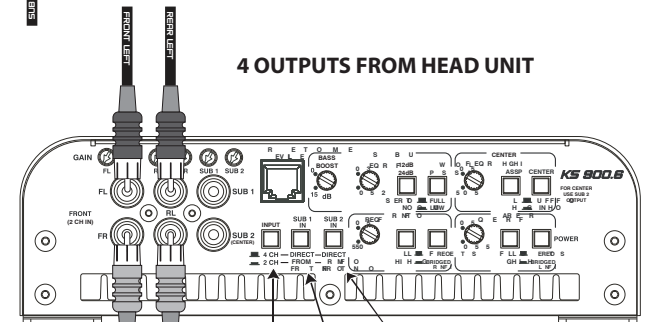

4 OUTPUTS FROM HEAD UNIT

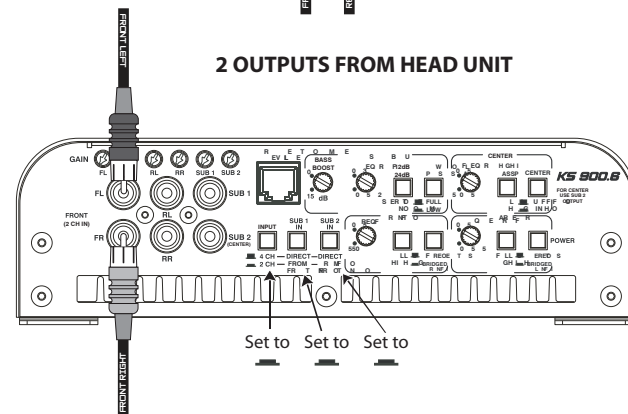

2 OUTPUTS FROM HEAD UNIT

KS 900.6 STEREO 4 CHANNEL WITH BRIDGED SUBWOOFERS

In this configuration 4 channels are used in High Pass for component or coaxial speakers and the Sub channels are Bridged.

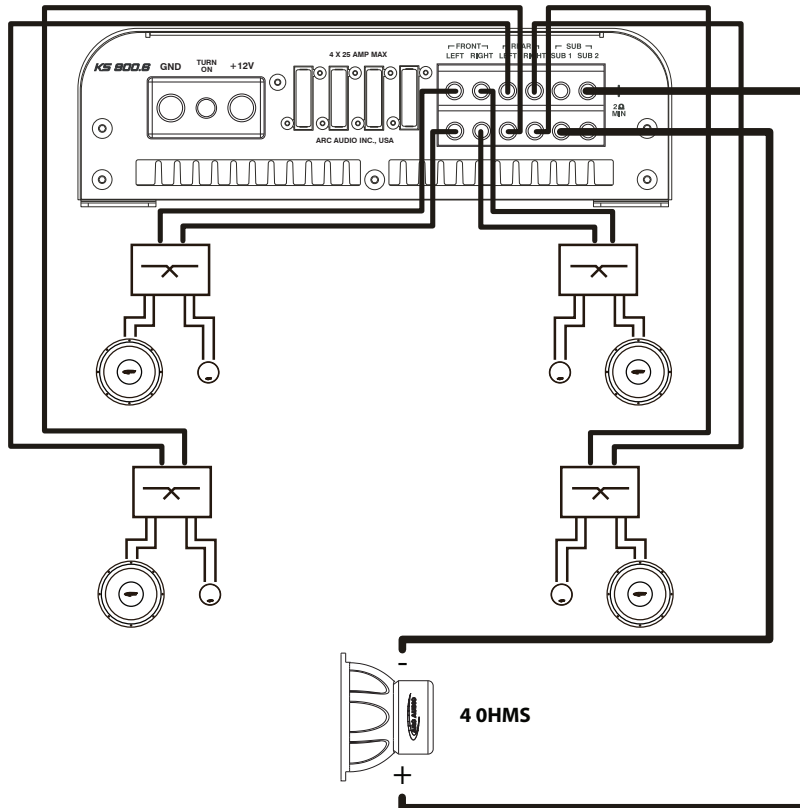
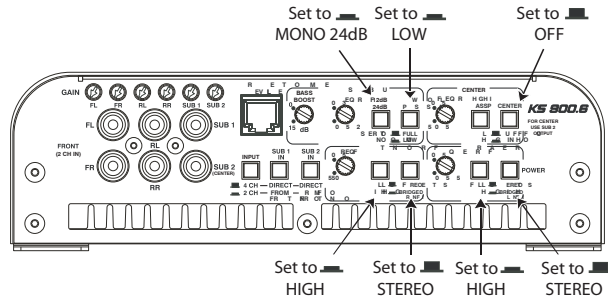

KS 900.6 STEREO 4 CHANNEL WITH MONO SUBWOOFERS

In this configuration 4 channels are used in High Pass for component or coaxial speakers and the Sub channels are wired independently but are set in Mono.

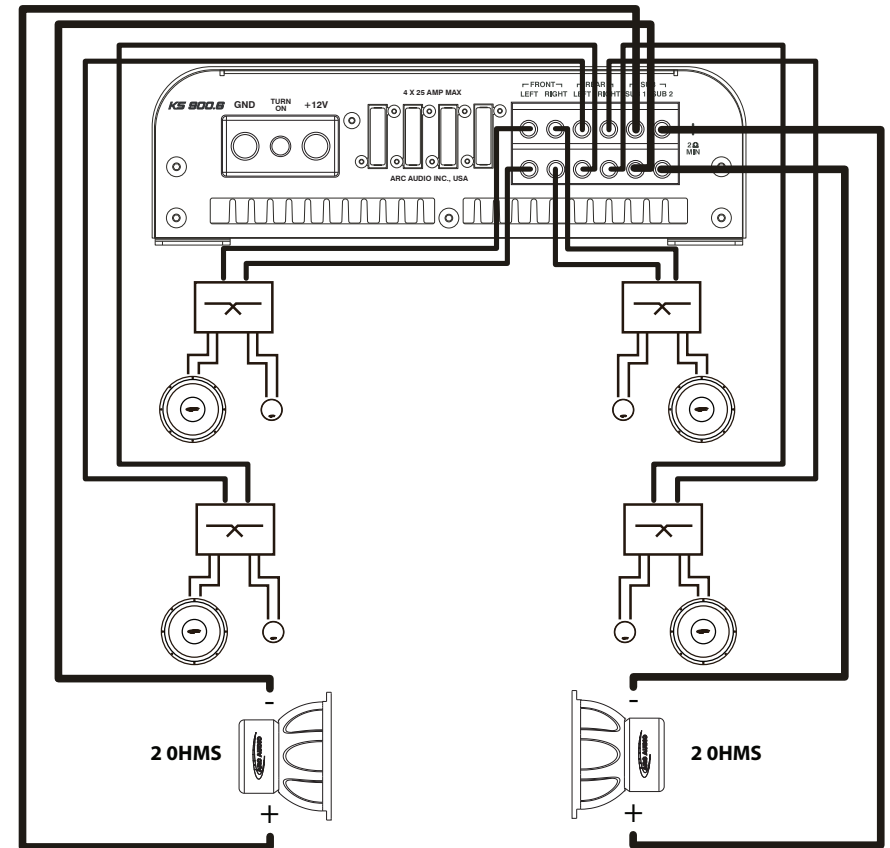
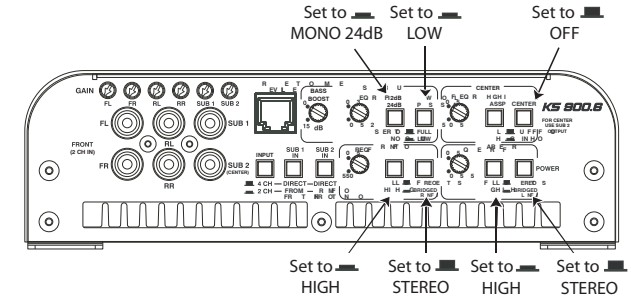

KS 900.6 STEREO 5 CHANNEL WITH BRIDGED SUBWOOFERS

In this configuration 4 channels are used in High Pass for component or coaxial speakers. The Sub 1 channel is used to drive a 2 ohm woofer. The Sub 2 Channel is selected as a High Pass Center Channel. This can be driven by a surround sound processor for a full 5.1 system.

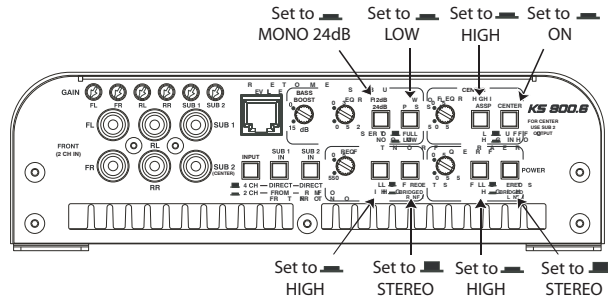

KS 900.6 STEREO 6 CHANNEL STEREO

In this configuration all 6 channels are used to drive component or coaxial speakers. The Sub channels are wired independently and set to "STEREO 12dB". The Sub crossover is set to "FULL".

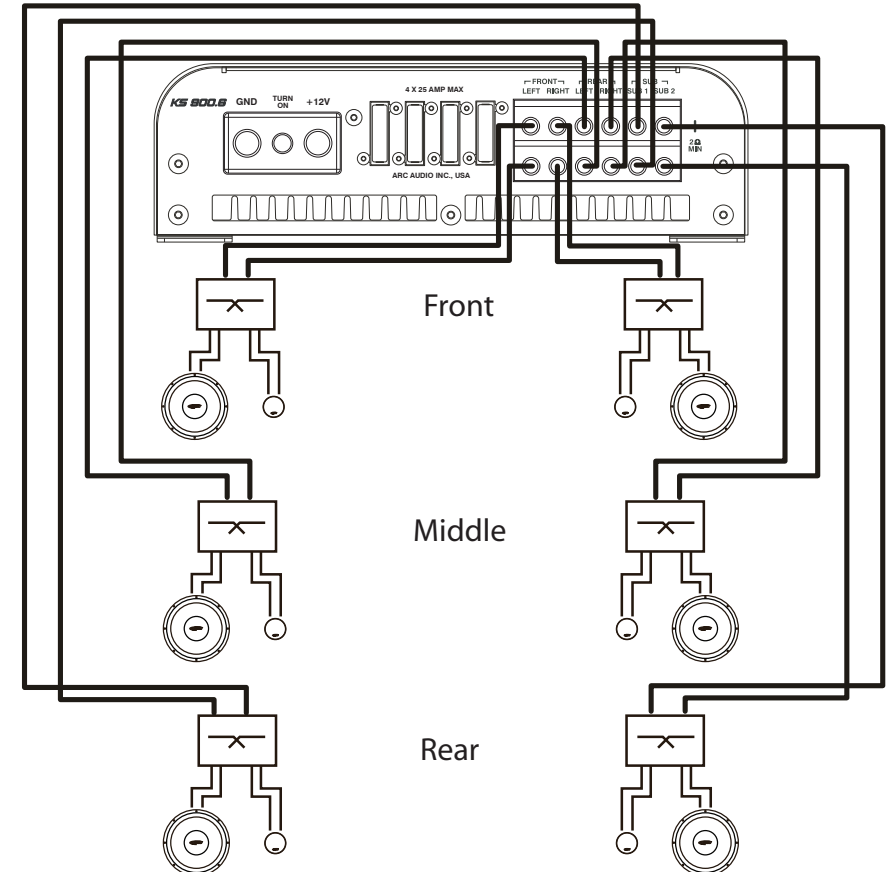
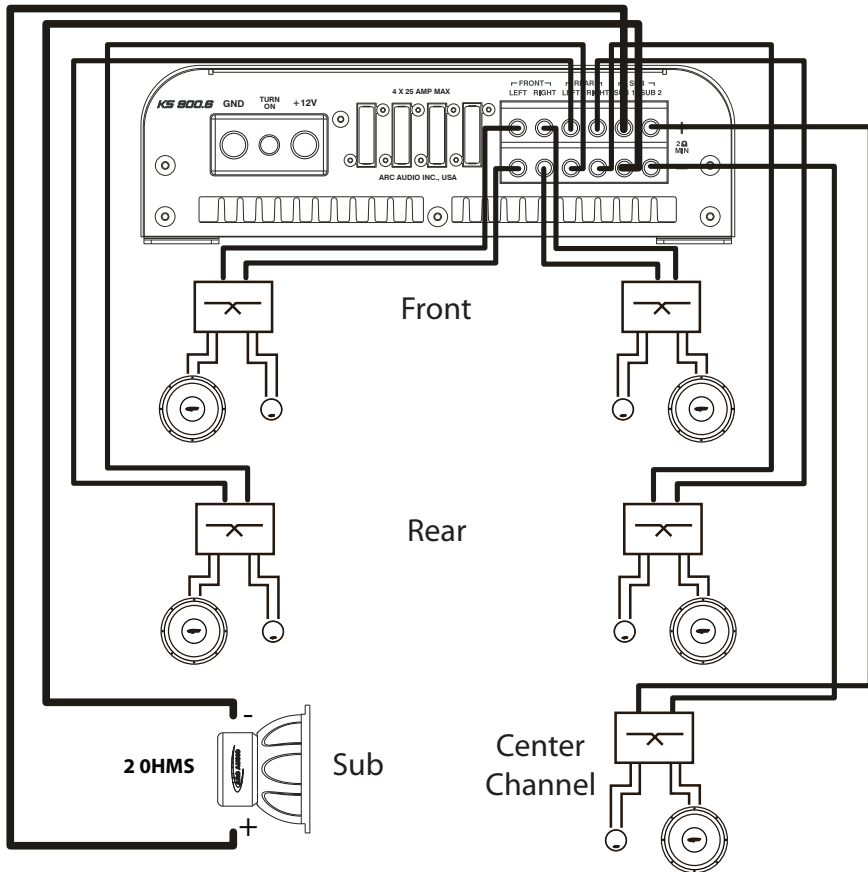
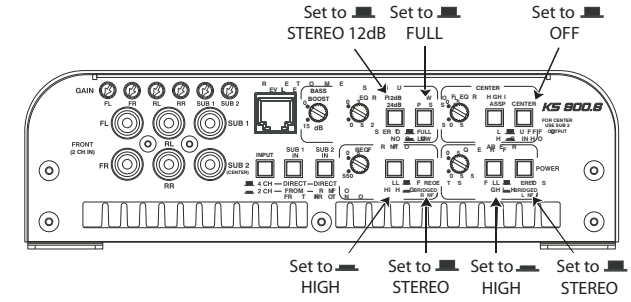

ARC AUDIO WARRANTY AND SERVICE GUIDELINES

KS 900.6 STEREO 2 CHANNEL BRIDGED WITH BRIDGED SUBWOOFERS

In this configuration the Front and Rear 4 channels are Bridged into 2 channels in High Pass for very high power (4 ohm only) component or coaxial speakers. The Sub channels are Bridged into a 4 ohm woofer.

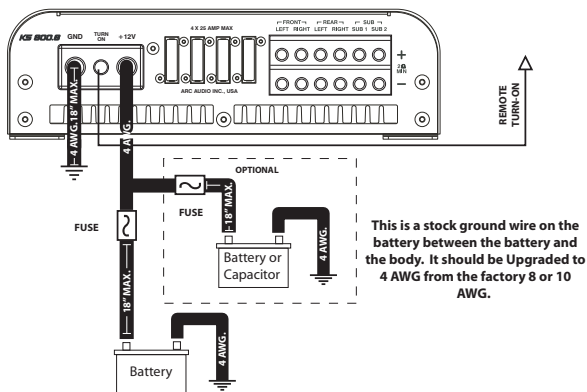
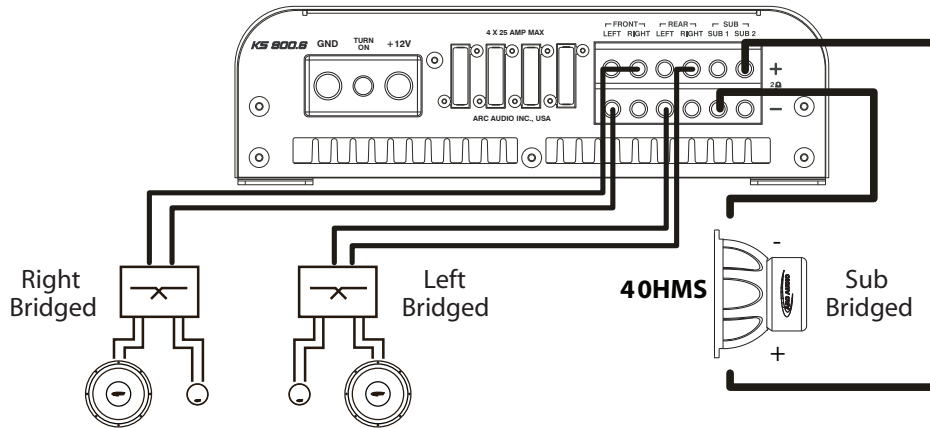
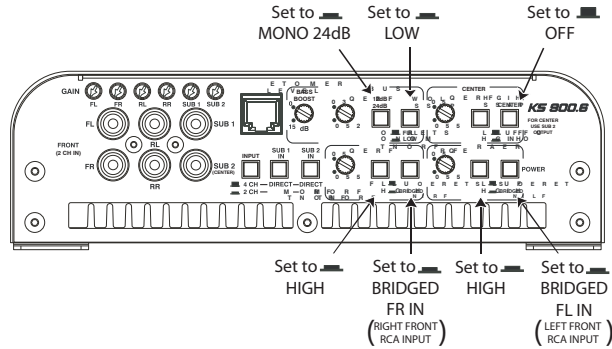

This is a stock ground wire on the battery between the battery and the body. It should be Upgraded to 4 AWG from the factory 8 or 10 AWG.

POWER CONNECTION

Take care with all power connection. It is important to use proper fusing at all sources of electrical power. This includes Batteries, and Capacitors. Proper grounding will insure a electrical power. This includes Batteries, and Capacitors. Proper grounding will insure a

ARC AUDIO warrants all new products against defects in material and workmanship for a period of ONE (1) YEAR from the original date of purchase from an AUTHORIZED ARC AUDIO RETAILER. This warranty is not transferable and applies only to the original retail purchaser of the product from an authorized ARC AUDIO retailer. Upon inspection by ARC AUDIO should services be necessary under this warranty for any reason due to manufacture defects ARC AUDIO will, at its sole discretion, repair or replace the defective product with new or similar conditioned product at no charge.

THIS WARRANTY DOES NOT COVER INSTALLATION OR DAMAGE RESULTING FROM ACCIDENT, MISUSE, ABUSE, IMPROPER WIRING, OPERATION OUTSIDE OF UNIT OUTSIDE OF MANUFACTURES SPECIFICATIONS, OR AGAINST INSTRUCTIONS IN OWNERS MANUAL. IN ADDITION ANY PRODUCT THAT HAS BEN OPENED, TEMPERED WITH OR MODIFIED, OR IF ANY SERIAL NUMBERS HAVE BEEN REMOVED OR ALTERED WILL NOT BE COVERED BY ANY PART OF THE MANUFACTURES WARRANTY.

All warranty returns should be sent to ARC AUDIO freight prepaid and must be accompanied by proof of purchase (a copy of the original sales receipt). Direct returns from consumers or non-authorized retailers will be refused unless specifically authorized by ARC AUDIO with a valid return authorization number.

All warranty returns must be packed in original packaging and be accompanied by a copy of the original printed sales receipt. Product damaged in shipment due to improper packaging will not be covered under this warranty and the customer or retailer will be charged full cost to repair the specific piece of product back to a like new or similar condition.

In no event will ARC AUDIO be liable for incidental, consequential, or other damages resulting from the use of this product, this includes but is not limited to, damage of hearing, property or person, damage based upon inconvenience or on loss of use of the product, and to the extent permitted by law, damages for personal injury. This warranty gives you specific legal rights, and you may have other rights, which vary from state to state. This warranty applies to products sold and used in the United States of America. In all other countries please contact your distributor.

The following are examples of what is not covered under Arc Audio's warranty policy-

- Any Product that is missing or has altered/damaged Serial numbers
- Any Product that has been damaged as a result of physical abuse
- Any Product that has been modified or altered from its original form or design and/or repair has been attempted by unauthorized repair facilities.
- Any product that has been previously owned by another use and was sold private party. (Arc Audio's warranty policy is not transferable to third party or second hand users)
- Any product purchased from ANY form of online marketplace (web sites, EBay or similar auction site, web site talk forum sales, etc)
- Any product not purchased at a brick and mortar authorized store front location.
- Any Speaker or Subwoofer than has been damaged to over-powering causing burnt voice coils and/or mechanical failures such as ripped spiders or surrounds.
- Product that has not been installed as per manufacture recommendations including wiring and installation related damage to product.
- Cosmetic damage due to installation, shipping and handling, and normal wear and tear.
- Arc Audio will not be responsible for any product that has any kind of custom finish or customized cosmetic additions that differs from the original form as manufacture from Arc Audio. Products damaged by "Acts of God" (Flood, Fire, Infestations, etc.)

For warranty and non-warranty repairs, send to:

ARC Audio
4719 Greenleaf Cr. #4
Modesto CA, 95356
209-543-8706



900_manual_VER1-02MichaelTyner Alsbury