

X2 1100.5

FULL-RANGE CLASS D AMPLIFIER

OWNER'S MANUAL

Table of Contents

<u>Topic</u>	<u>Page</u>
Introduction	2
Finding a Suitable Location	2
Supplying Power	2
The Ground Connection	2
Running Cables	2
Class D Amplifier Recommendations	3
Diagnostic Fault Codes	3
Speaker Level Input Pigtailed	3
Input Section	4
Gain / Sensitivity Controls	4
Crossover Controls	4
Crossover Range and Function Controls	4
Bass Boost	5
Bridging Mode	5
Input Select Switches	5
Load Impedance	5
Speaker Output Connections	6
Power, Ground and Turn-On Connections	6
Fuses	6
Auto-Sense Turn-On Detection	6
Remote Level Control	7
Accessing Controls and Mounting Provisions	7
Installation Instructions	8
Stereo 4-Channel High-Pass w/ Sub Configuration	9
Bridged 2-Channel High-Pass w/ Sub Configuration	10
Stereo 3-way Active Configuration	11
Specifications	12
Warranty	12

Thank you for purchasing an ARC Audio High-Performance Amplifier!

This ARC Audio amplifier uses a Full Range Class D architecture that significantly improves efficiency, lowers heat generation and reduces current consumption. Don't be fooled by the small size. Class D amplifiers make more power per square inch than traditional designs. This compact size makes installation a breeze without compromising storage space.

ARC Audio...**SOLID CONSTRUCTION** for **SOUND** Car Audio Systems.

Warning!!

We build all ARC Audio products to play at high volumes for extended periods of time. Your ears however are not designed for extended listening at high volume levels. This product can easily generate volume levels that can permanently damage your hearing. We urge you to limit your exposure to very high volume sound.

You may also find your state has laws governing the volume of an audio system in a car. Please be aware of all local and state laws in your area.

A properly tuned and operated audio system will deliver years of enjoyment when used properly.

Installation Instructions

ARC Audio X2 Amplifiers are designed for easy installation in your vehicle. To ensure the proper operation of your new purchase, please follow the suggestions we have listed below:

Warning

Please check the suitability of the installation location before you begin. Do not cut any of the car's structure. Pay close attention to what is behind the panels or carpet. Often, vehicle manufacturers will hide wires, fluid lines, computers or other electronic devices in the exact area you want to mount and amplifier or drill a hole to run a wire.

If you do not have experience with automotive electrical and mechanical systems contact a professional installer. Paying for a qualified installer is almost always cheaper than paying a dealership to repair your car.

Locating the Amplifier

The amplifiers must be securely mounted to a solid surface. Please select a dry location in the trunk or passenger compartment only. Do not mount the amplifier to any area that may experience excessive vibration (like side of a subwoofer enclosure). Position the amplifier in an area that receives sufficient airflow for proper cooling.

Supplying Enough Power - The Laws of Physics

Your amplifier Does NOT make power. It converts power, from your vehicles electrical system and turns it into high-power musical energy. If the amp can't get the power it needs from your alternator and battery, it will not be able to produce its full output. Your ARC Audio amplifier will produce full output for longer than other amps on the market today. If the Voltage or Current drops too low, even our amplifiers will drop below their rated output. Make sure your vehicle charging system is in good working order. Any high-performance audio amplifier will increase the demand on your alternator and battery. If you are unsure of the condition of electrical system, have your charging system tested by a professional technician.

The Ground Connection!!! Warning: Read this Carefully

The ground connection is as important as the power connection in terms of supplying power to your amplifier. If you are working on a late-model vehicle, it may be necessary to ground your amplifier directly to the chassis of the vehicle AND run a parallel ground wire to the negative terminal of your battery. Modern vehicles make extensive use of adhesives to join panels together. These adhesives don't conduct electricity.

When connecting the ground wire to the chassis, find a clear and safe location close to the amplifier, and remove all the paint and sound deadening. Use a large nut and bolt to secure the ground wire. Never use seat belt bolts for grounding.

Remember, the ground must carry the same high current as the positive power wire.

To reduce the risk of noise, run all signal cables away from any vehicle or power supply wiring.

Running the Cables

Take care when running the power and signal cables through the passenger compartment of the vehicle. Running power down one side and signal down the other is the preferred method. If this isn't possible, keep them as far apart as possible. When running through any metal, always use a rubber or plastic grommet to prevent the power wire from shorting and to reduce the risk of fire. A 4 AWG or larger wire should be used for power and ground connections.

ALWAYS install a fuse on the power wire as close to the positive battery terminal as possible - preferably within 6 inches.

Recommendations for all Class D amplifiers

Class D amplifiers, by the nature of their design, can emit a certain amount of Radio Frequency (RF) noise. While we have optimized the design to reduce this to a minimum, there are still steps you can take to eliminate unwanted FM radio interference. The tips below apply to all class D amplifiers.

- Always mount the amplifier as far from the radio antenna as the installation will allow.
- Keep the amplifier away from the radio or any other electronics that may prove to be sensitive to RF noise.
- Make the ground wire as short as possible.
- Use twisted pair wires as much as possible. If possible, all the speaker wire and input cables should be twisted. If you do not have twisted pair wire you may be able to twist it yourself.
- If you encounter a problem with FM interference you can try turning the amplifier 90 degrees or changing its location completely. RF noise can be very directional.

Warning!

Take extra care when using CCA (Copper Clad Aluminum) or pure aluminum wire. Ensure all connections are clean and tight. Due to the highly reactive nature of aluminum, electrical connections can fail without the typical "Green" or tarnished look you would expect with copper. Aluminum also has a greater rate of expansion due to heat and care must be taken to ensure that connections are not over tightened. This can result in the failure of the power or ground connector and cause damage to your amplifier.

Where possible, always use all-copper conductors for power, ground and speaker wire connections to reduce the potential for connection problems.

Diagnostic Fault Codes

All ARC Audio X2-Series amplifiers feature microprocessor controlled error reporting to help your installer diagnose potential issues. The following chart explains what each of the error codes mean.

Thermal Error (Heatsink) The Amplifier has Over Heated. Turn the volume down and let it cool off.	Long Long Long ● ● ● ● ○ ● ● ● ● ○ ● ● ● ● ○ ○
Thermal Error (Transformer) The Power Supply Transformer has Over Heated. Turn the volume down and let it cool off.	Short Long Short Long ● ● ○ ● ● ● ● ○ ● ● ○ ● ● ● ● ○
Code 11 Under Voltage The Battery Voltage is too low. Check your battery, alternator and wiring.	Short Flash ● ● ○ ● ○ ○ ○ ○ ○ ○ ○ ○ ○ ○ ○ ○ ○ ○ ○ ○
Code 12 Short (Low Power Channel) Shorted speaker or wire on Channels 1-4. Turn the system off until you can get this fault corrected. Also includes internal shorts.	Short Flash Flash ● ● ○ ● ○ ○ ○ ○ ○ ○ ○ ○ ○ ○ ○ ○ ○ ○ ○ ○
Code 13 Repeated Shorts You didn't turn the system off, did you? See Code 12	Short Flash Flash Flash ● ● ○ ● ○ ● ○ ● ○ ○ ○ ○ ○ ○ ○ ○ ○ ○ ○ ○ ○ ○ ○ ○
Code 14 Over Voltage Your Alternator is producing too much voltage. Have your vehicle's electrical system tested right away.	Short Flash Flash Flash Flash ● ● ○ ● ○ ● ○ ● ○ ● ○ ● ○ ● ○ ○ ○ ○ ○ ○ ○ ○ ○ ○ ○ ○ ○ ○ ○ ○
Code 15 DC Output Protection DC Current was detected on the speaker outputs. To avoid damaging the speakers, this amplifier has shut down. This will probably require factory service.	Short Flash Flash Flash Flash Flash ● ● ○ ● ○ ● ○ ● ○ ● ○ ● ○ ● ○ ● ○ ○ ○ ○ ○ ○ ○ ○ ○ ○ ○ ○ ○ ○ ○ ○
Code 16 Short (High Power Channel) Shorted speaker or wire on subwoofer channels (5 or 5-6) also includes internal shorts.	Short Flash Flash Flash Flash Flash Flash Flash ● ● ○ ● ○ ● ○ ● ○ ● ○ ● ○ ● ○ ● ○ ● ○ ○ ○ ○ ○ ○ ○ ○ ○ ○ ○ ○ ○ ○ ○ ○
Normal Turn on Blue is good. This is the normal start-up self test and turn-on delay.	Short Flash Flash Flash Flash Flash Flash Flash ● ○ ● ○ ● ○ ● ○ ● ○ ● ○ ● ○ ● ○ ● ○ ○ ○ ○ ○ ○ ○ ○ ○ ○ ○ ○ ○ ○ ○ ○
Power/Processor Reset You will see this the first time the amplifier is powered up or after the microprocessor resets. This code will vary from model to model.	Short Short Flash Flash Flash Flash ● ● ○ ○ ● ● ○ ● ○ ● ○ ● ○ ● ○ ● ○ ○ ○ ○ ○ ○ ○ ○ ○ ○ ○ ○ ○ ○ ○ ○

Speaker Level Input Pigtails

All ARC Audio X2-Series amplifiers include a set of high-level speaker input RCA pigtails. These pigtails include a resistive voltage divider network to reduce the signal from a high-power source unit or factory amplifier so that it can be used with the differential Inputs on your X2-Series Amp. The following outlines the polarity of the connections for the input pigtails.



Input Section

This X2 Series amplifier is equipped with a balanced differential input stage that is compatible with any analogue source including Balanced and Unbalanced RCA, Common ground speaker level output and Bridged Tied Load (BTL) outputs common to many OEM head units. The RCA pigtails included with these amplifiers are intended to be used with the speaker-level outputs of a radio or amplifier. These pigtails include a divider network molded into the RCA end that reduces the voltage of the signal from the source. If you are integrating into an OEM system with balanced or common ground line-level signals you should not use these Pigtails. In this case it is recommended that you use an appropriate RCA cable with one set of ends removed as inputs for the amplifier.

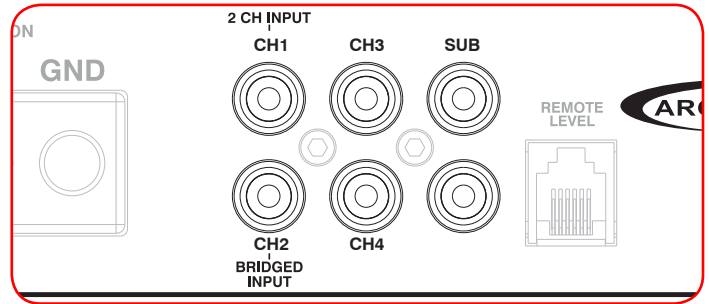

Gain / Sensitivity Controls

Because of the wide range of head unit output configurations available, all ARC Audio amplifiers have an adjustable input sensitivity or "Gain" control. The gain is not a volume or a power limiting control like a throttle. It makes the amp more sensitive to input from the source. With the gain up the amp will reach full output at a lower volume setting on the deck and becomes more sensitive to noise from the car's electrical system. Try to run the gain at the lowest setting possible for your system.

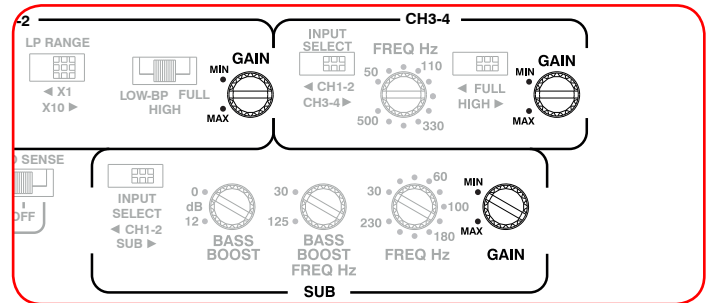

There is no correct gain setting. As different size and shape speakers require different amounts of power to reach the same output, the gain settings need to be adjusted to compensate for these speaker efficiency differences. If you tried to set all the gains at half way you would probably find the system didn't sound very good. Use good judgment and optimize each channel carefully as you configure the system. You want to set the gains to maximize the output of the amplifier, while producing minimal distortion for your given source unit and music selection.

Crossover Controls

A crossover is a circuit that limits what frequencies are produced by the amplifier, and subsequently, the speaker(s) connected to the amp. A tweeter can be destroyed by bass information. Those frequencies need to be filtered for proper operation. Likewise, a subwoofer will not sound natural if it is playing midrange frequencies. A crossover removes these sounds from the signal going to the speaker. As you might guess, careful adjustment is required to ensure that all the speakers are playing in the correct frequency range and that the net frequency response of the total system is smooth with no over- or under-lap.

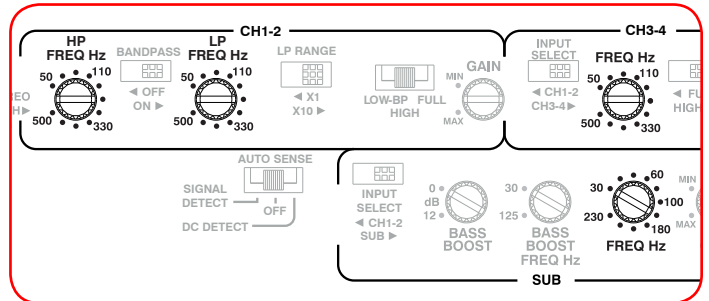

Crossover Range and Function Controls

The X2 1100.5 includes the option for High-Pass, Low-Pass, Band-Pass or full range operation from Channels 1 and 2. Channels 3 and 4 offer High-Pass or Full-Range Operation. The subwoofer channel has a Low-Pass crossover in operation at all times.

For Channels 1 and 2 set the Crossover Function switch to LOW-BP and set the BANDPASS switch to ON in order for both the High-Pass and Low-Pass Filters to function simultaneously. The LP RANGE Switch in the X1 setting offers a crossover range of 50 to 500 Hz. In the X10 position, the Low-Pass crossover range is 500 to 5 kHz. When the Crossover function switch is set to HIGH, only the High-Pass filter is active.

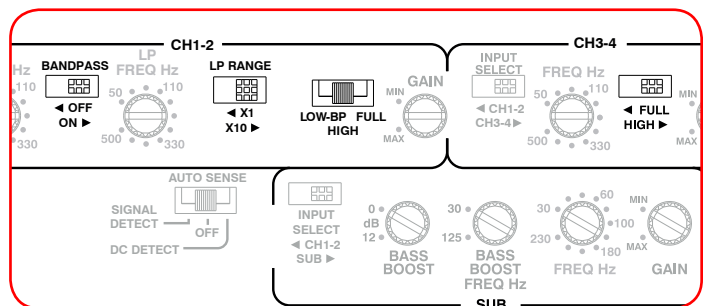

On Channels 3 and 4, the Crossover Function switch selects between Full-Range and High-Pass filtering.

Bass Boost

This amp has an adjustable Bass Boost acts like a single-band para-graphic equalizer on the subwoofer channel. Use the Bass Boost control carefully. Increasing low-frequency output puts tremendous demands on the speaker and amplifier.

The BASS BOOST control determines how much boost is applied to the signal and is adjustable from 0 to +12dB. The BASS BOOST FREQ Hz control determines that frequency around which the signal boost is provided and is adjustable from 30 to 125Hz.

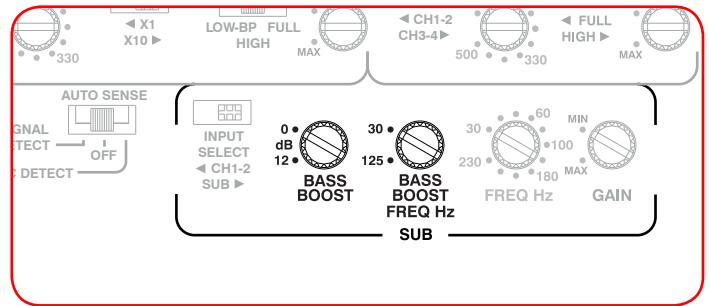

Bridging Mode

The X2 1100.5 features a master INPUT SELECT switch that selects between five- and three-channel operation.

The left-most INPUT SELECT in the BRIDGED 3CH mode sends the signal on CH1 to Channels 1 and 2 and the input signal on CH2 to Channels 3 and 4. The crossovers and controls for CH1-2 should be used to adjust these signals.

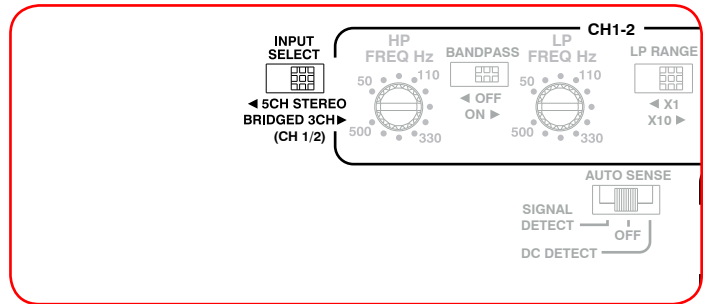

Input Select Switches

The X2 1100.5 features two additional INPUT SELECT switches to help simplify installations and system configuration where only one or two sets of speaker wires or RCA's is available to connect to the amplifier or when you want to use this amp in three-channel mode.

The INPUT SELECT switches on Channels 3 and 4 and the SUB Channel can be used in lieu of RCA Interconnect Y-Cables to route signals from Channels 1 and 2 to these respective outputs.

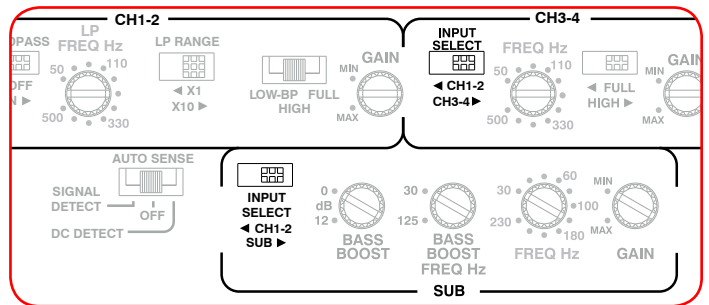

Load Impedance

A unique feature of the X2 1100.5 is its adjustable rail voltage system. Each pair of channels includes a LOAD SELECT switch.

Under 4Ω - Any speaker or combination of speakers with a total combined impedance between 2 and 4 Ohms (not lower than 2 Ohms) must use this position. Bridged loads down to 4 Ohms must use this position. The amplifier will make full power at 2 Ohms Stereo (4 Ohms bridged).

Over 4Ω - Any speaker or combination of speakers with a total combined impedance at or above 4 Ohms can use this position. The amplifier will make full power at 4 Ohms stereo (8 Ohms bridged).

The SUB channel is designed to drive a 2-Ohm load. Higher impedances are acceptable, but will result in decreased power production.

WARNING: This amplifier will not operate and could be damaged if used with the LOAD SELECT switches in the wrong configuration. At no time can it be operated below 2 Ohms stereo or 4 Ohms when bridged.

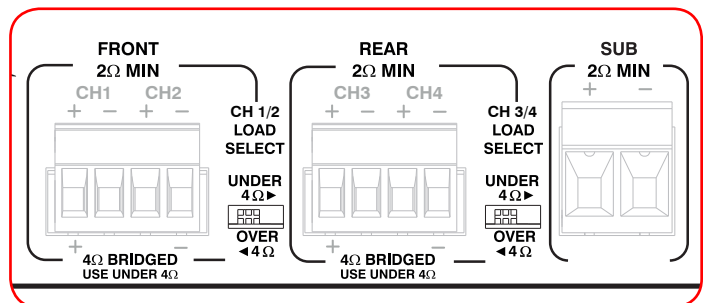

Speaker Output Connections

This amplifier features a multi-channel design. This means, it has more than one pair of speaker outputs. It is equipped with set of removable plug-style terminals for speaker wire connections up to 14 AWG in size. Make these connections carefully and neatly. Strip the wire back 5/16", twist the exposed leads together tightly, and insert them into the block terminal while being careful that there is no loose or frayed strands of wire touching adjacent wires or connections. Tighten the flat-head set screw on the terminal until the wire is held in place securely. The amplifier will go into protection if the wires ever come in contact

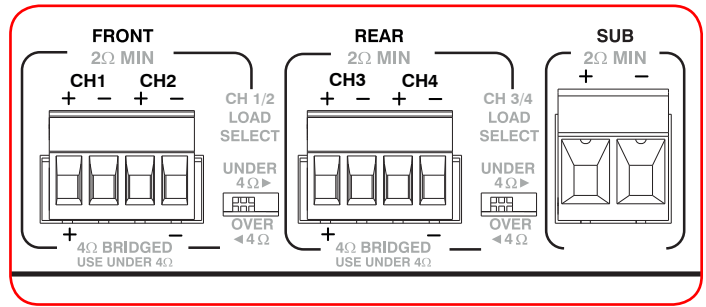

Power, Ground and Turn-On Connections

The X2 1100.5 features a terminal block that is designed to secure 4 AWG power and ground connections to the amp. We recommend the use of pure copper power and ground wires in order to achieve the most reliable connections. Also, be wary of 4 gauge versus 4-AWG wire. The American Wire Gauge (AWG) is a universal standard that specifies the diameter of stranded conductors. Wiring that is labelled as '4 gauge' may not be adequate to supply the amp with the current it requires to operate reliably and efficiently.

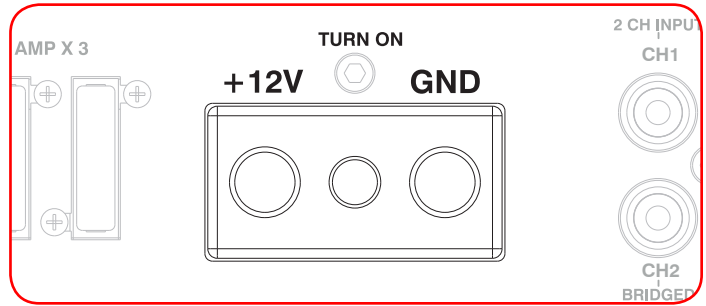

The Turn On input should be connected to the amplifier +12V DC remote turn-on output of your after-market source unit. In most cases this is a blue wire with a white stripe. Note: On some source units, there are power antenna AND remote turn-on wires. If you only hear audio when listening to the AM/FM tuner, your amp may be connected to the wrong wire.

Fuses

The X2 1100.5 includes three 30 amp ATC/ATO fuses on the left side of the end-panel. These fuses exist to protect the internal circuitry of the amplifier from damage and are not a replacement for a proper fuse at the battery in your vehicle. Under no conditions should you increase the value of the fuses used in this location.

If the fuses blow immediately upon insertion, contact your authorized ARC Audio dealer or the Technical Support department at ARC Audio for assistance.

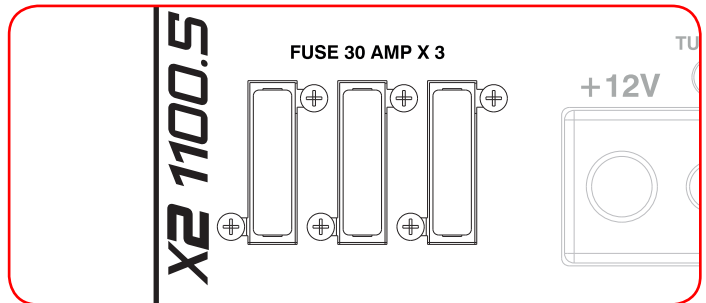

Auto Sense Turn-On Detection

The X2 1100.5 features two Auto-Sense Turn-On modes. In DC Detect mode, the amplifier monitors the Channel 1 RCA input for the presence of a DC offset voltage (common with Bridge Tied Load (BTL) source units and amplifiers). When this DC voltage is present, the amp will turn itself on.

When set to Signal Detect, the X2 1100.5 monitors the Channel 1 RCA input for the presence of an audio signal. When an audio signal is present, the amp will turn itself on.

The amp automatically turns off 10 seconds after the DC Detect or Signal Detect no longer sees an appropriate signal.

When using either Auto-Detect mode, only the Channel 1 input is monitored.

The Turn On input on the power terminal block is NOT used when Auto Detect is turned on.

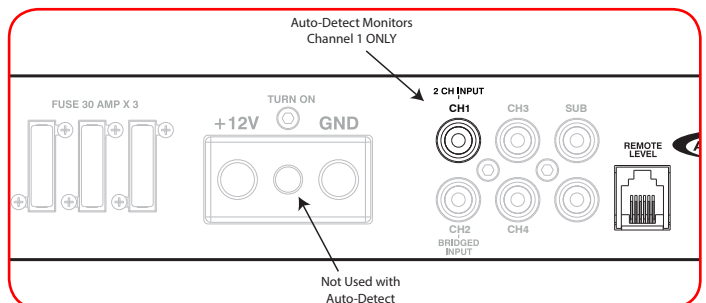
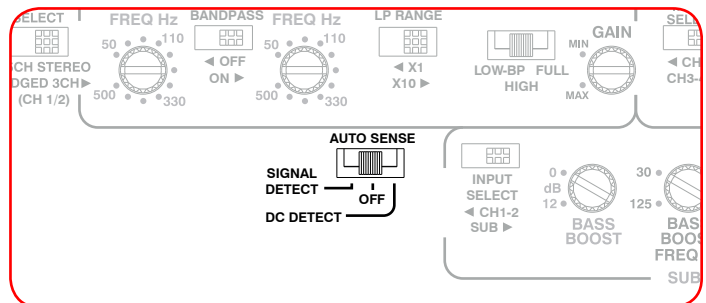

Remote Level Control

The X2 1100.5 ships with a remote level control that can be installed in near the driver's seat so the owner can adjust the level of a subwoofer. The Level control only affects the output of the SUB channel.

To set the gains on this amplifier, either leave the Remote Level Control disconnected or turn it to it's maximum setting (fully clockwise). The Remote Level Control functions as an attenuator so as not to alter the gain structure of the amp and cause distortion, unlike a remote bass boost control.

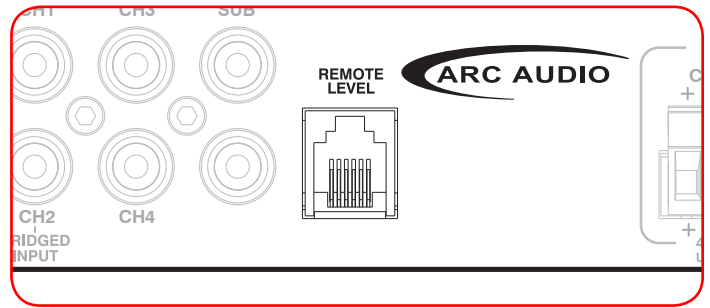

Accessing Controls and Mounting Provisions

The X2 1100.5 features our Level 2 X2-Series cosmetics. The amplifier shroud features an elegant new silver brushed-aluminum extruded aluminum design. An acrylic plastic badge in the center of the amp illuminates in blue when the amp is on, and can flash diagnostic codes as required. The badge may be rotate in 90 degree increments to suit any installation.

To access the controls on the top of the amp, remove the four screws in the badge and set them in a safe place. Remove the badge and set it in a safe place. The amp shroud can now be removed for tuning and installation.

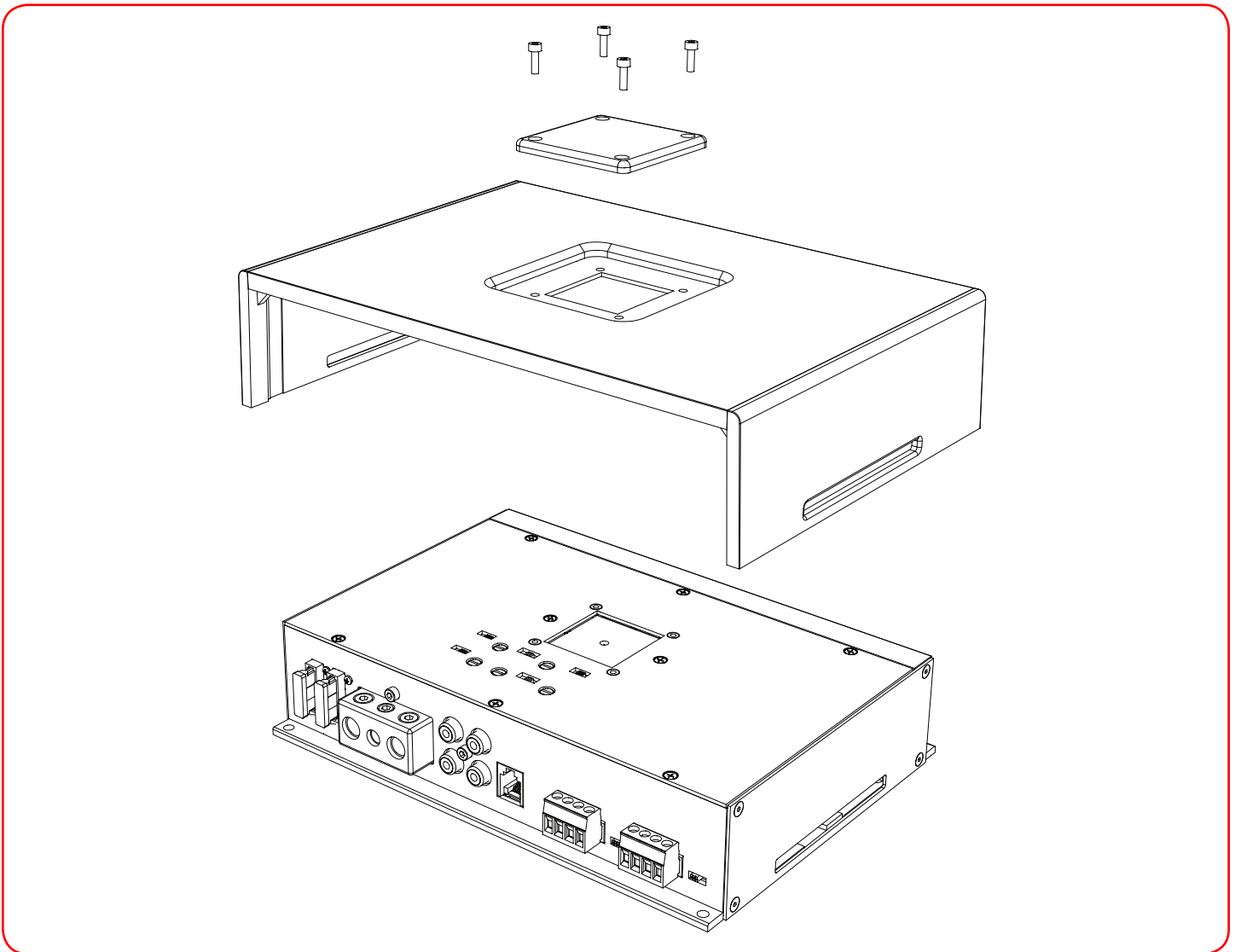

Amplifier shown represents X2-Series amplifier. Dimensions are not to scale.

Installation Instructions

Below is a very abbreviated set of installation instructions. This is not meant as a step-by-step procedure, but is intended to give you a general idea of what is involved in installing this amp and the order in which the process should be completed. Every installation will be different and may require reordering of these steps.

- NEVER install the fuse at the battery or connect the negative battery cable until all the connections have been finalized.
- Before you start, disconnect the negative cable from any and all batteries in the vehicle. Tape up or secure the ground lead so it is isolated from the battery.
- Run an appropriate gauge power wire from the battery to the amplifier. Plan this part of the installation carefully. This cable will carry large amounts of current. Should this wire short to the body of the vehicle and not be properly fused, it could easily cause a fire.
- Always use a rubber or plastic grommet when routing power wires through the firewall or any metal surface.
- Connect the power wire to the battery using a fuse that is capable handling the total current requirements of all amplifiers or devices connected to the wire. In cases where multiple amplifiers share a common power wire, ensure each device has proper protection with a fuse. The fuses built-in to the ARC Audio X2-Series amplifiers satisfy this need. Processors, lighting, etc. will require dedicated fuses for safe operation.
- Locate the vehicle protection fuse as close as possible to the battery. If the fuse is further than 18 inches (wire length) from the battery, you should re-evaluate the wire routing and fuse placement. Ideally, the fuse should be within a few inches of the positive battery terminal.
- Find the closest clear metal area to the amp for a the ground connection. Sand, grind or scrape all paint and undercoating from the body and use a nut, bolt and lock washer to secure the wire in place. If your vehicle uses Quiet Steel, composite body panels or may have been assembled using adhesives rather than spot welds, add a parallel ground between the ground location in the vehicle and the negative terminal of the battery to ensure proper power delivery.
- Run the speaker wires to the speakers. It is advised that you leave some extra wire at this point. You can clean it up later.
- If you haven't already done so, mount the amp now.
- Connect the power and ground cables to the amplifier.
- Only after this step should you install the fuse at the battery or batteries. Reconnect the negative battery lead at this point.
- Connect the remote wire from the head unit to the amplifier.
- Turn the amp on for the first time. Make sure it turns on properly and does not go into protection.
- Turn the system off and finish connecting the speaker wires to the amplifiers and speakers. Make sure the polarity (+ and -) is correct.
- Connect the RCA signal wires to the amp.
- Double check the amplifier controls at this time. Make sure everything is set correctly based on your system design.
- Now you're ready to play it for the first time. It is best to leave the gains all the way down at first. Start with the head unit volume low and work your way up.
- Now you can tune the amp. Take your time and make only one adjustment at a time. It may take some time to get the system adjusted for our choice of speakers and subwoofers. Be patient.
- Any time the system is on, large amounts of current may be drawn from the battery. Monitor the battery voltage carefully and charge it thoroughly if it gets low.
- That's it! You're done. Now have fun!

X2 1100.5

STEREO 4-CCHANNEL HIGH-PASS with SUBWOOFER

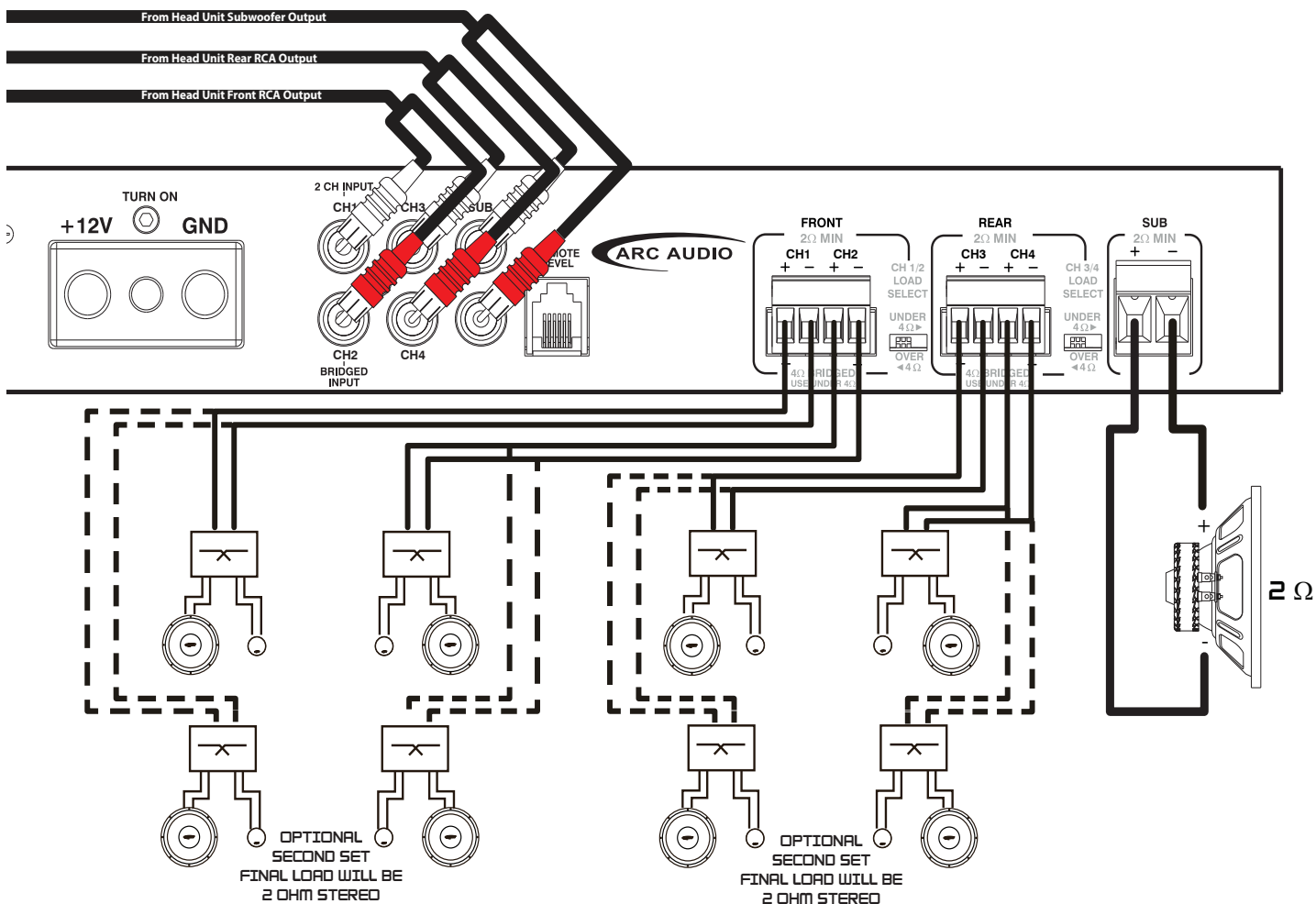
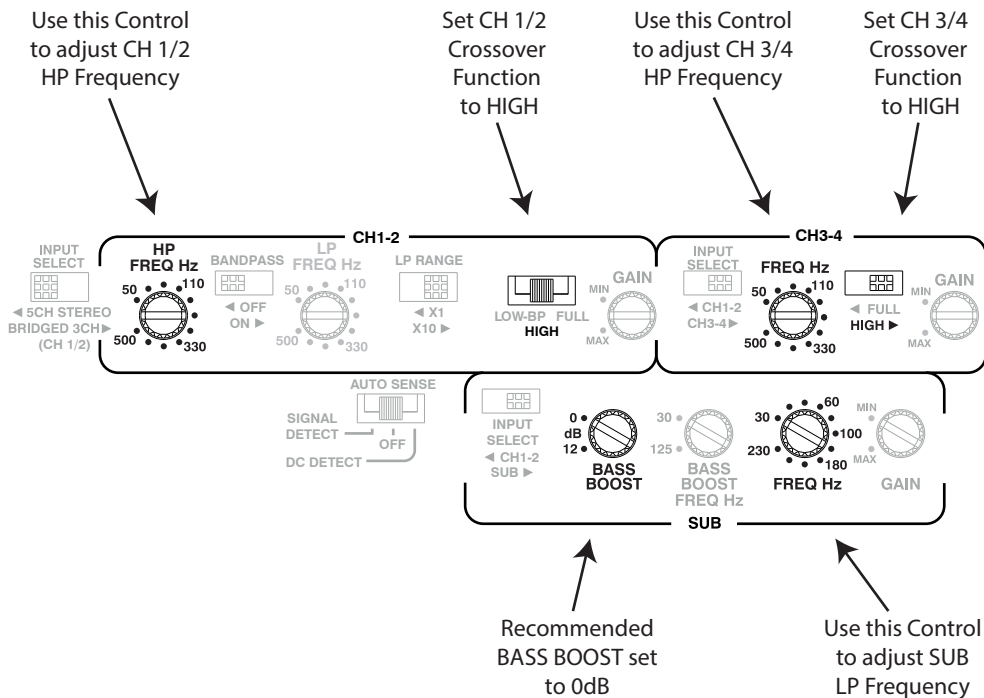

X2 1100.5

BRIDGED 2-CHANNEL HIGH-PASS with SUBWOOFER

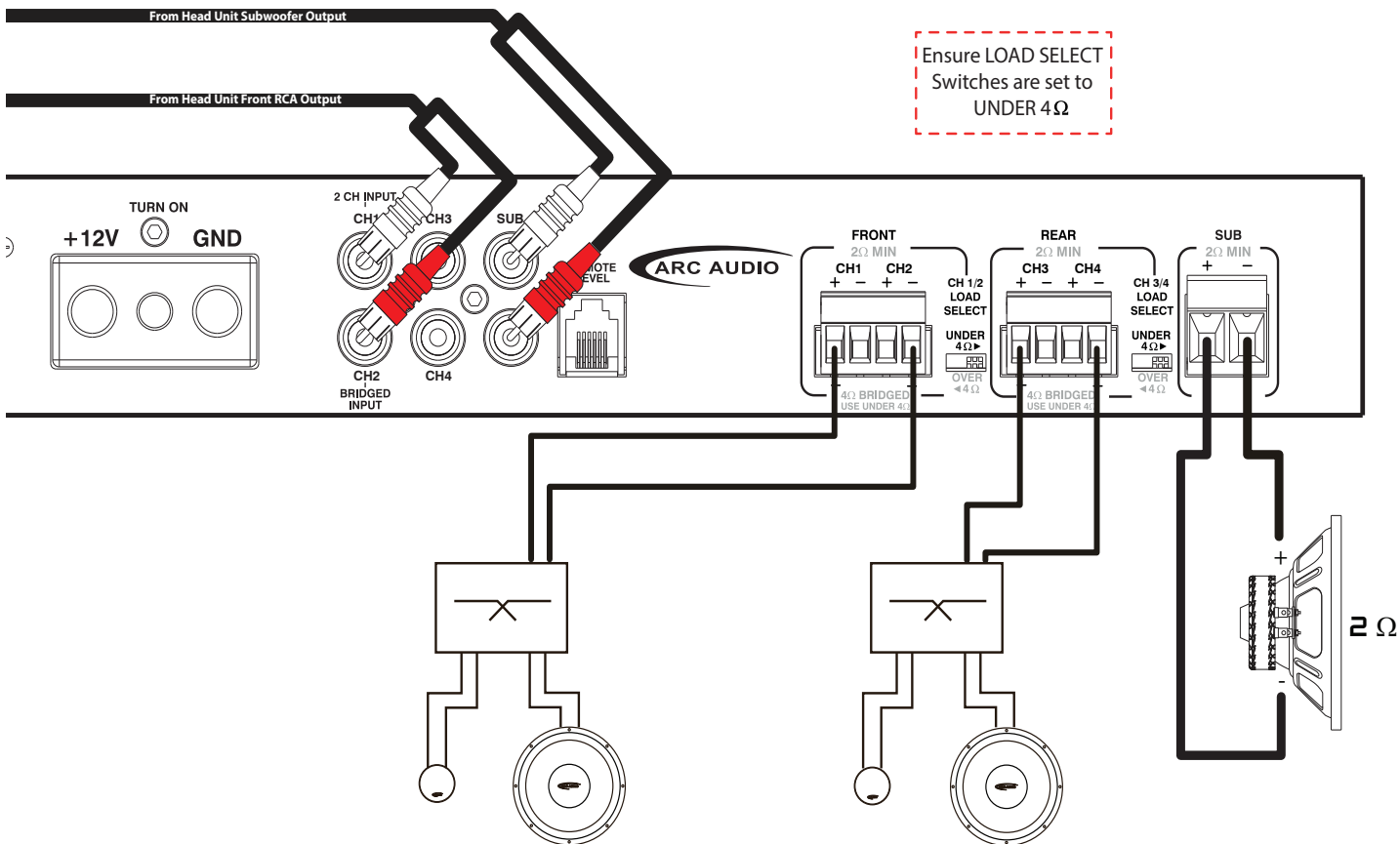
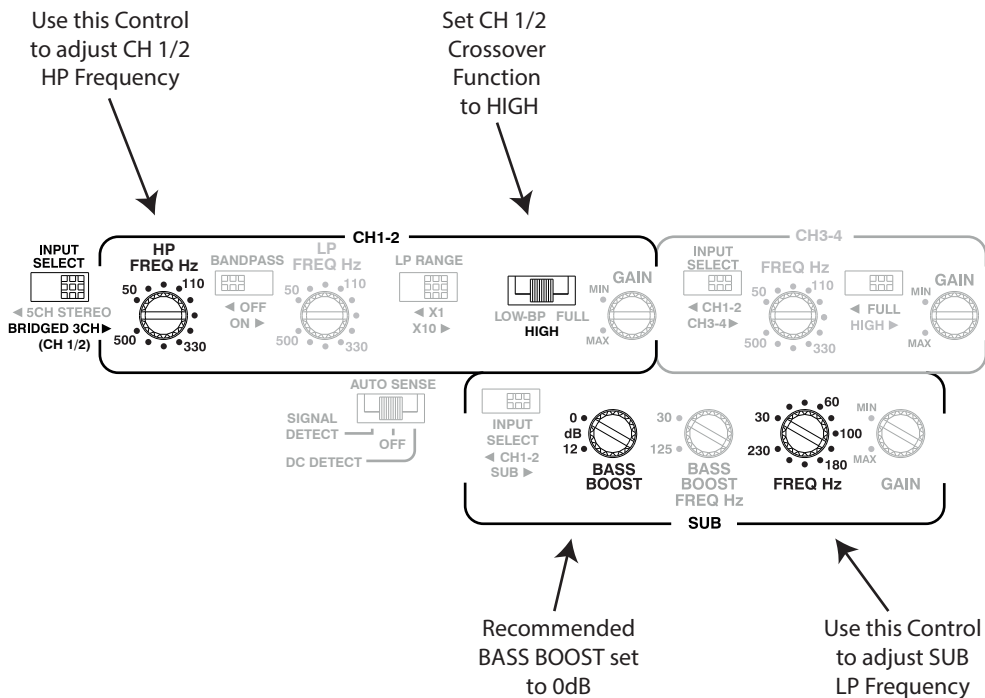

X2 1100.5

STEREO 3-WAY ACTIVE

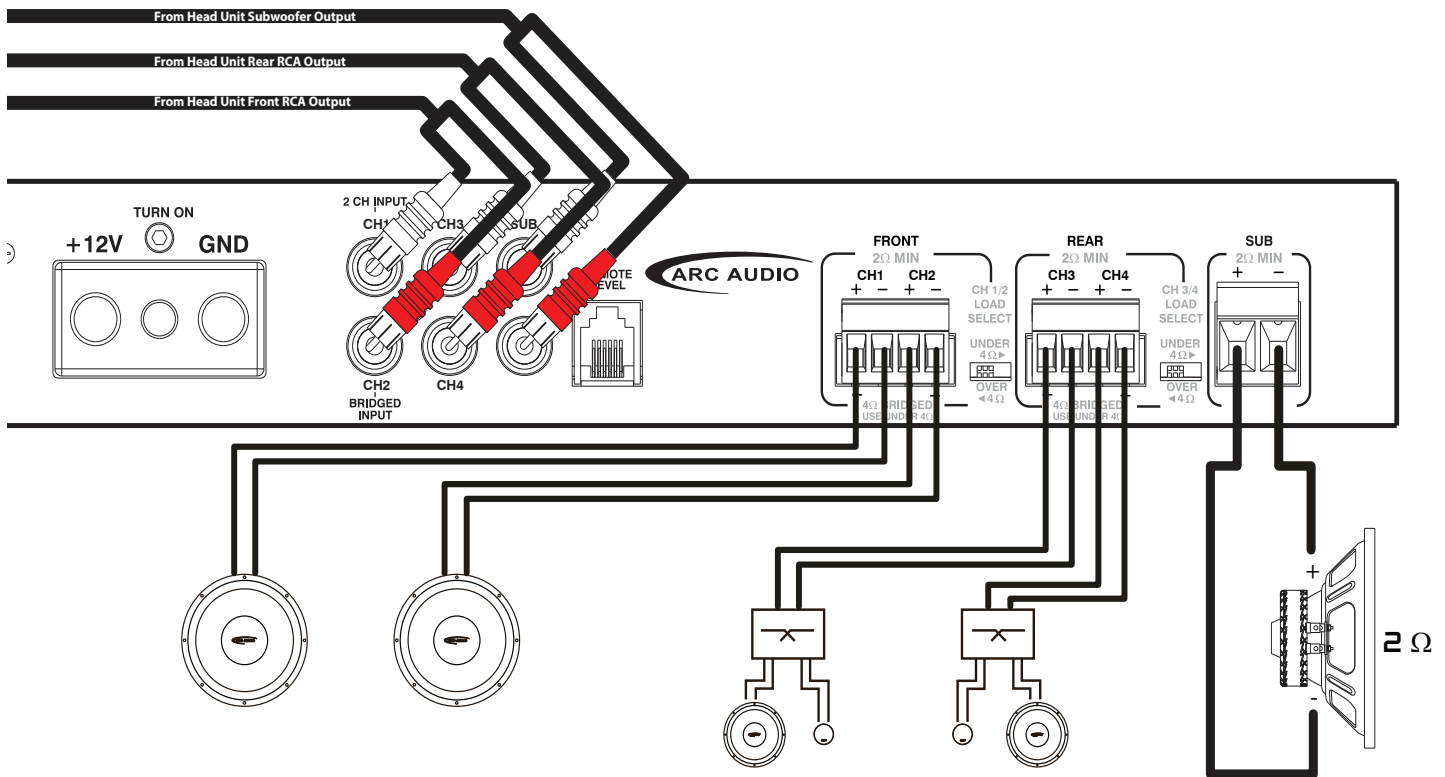
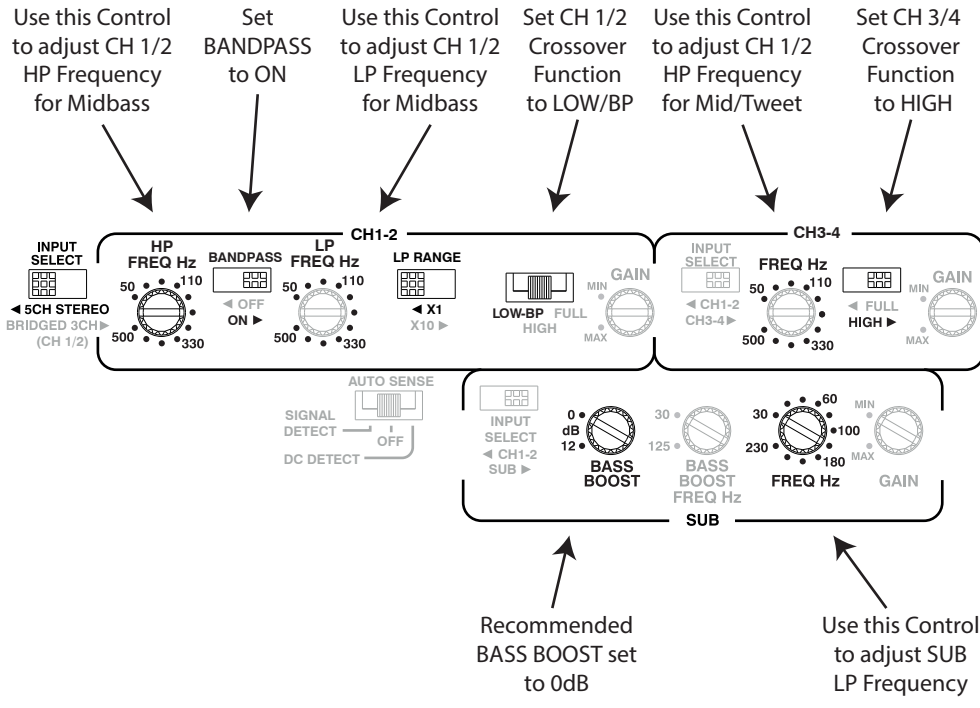

Door/Kick Panel
Midbass Drivers

Dash/Kick Panel
Mid and Tweet w/
Passive Crossover

X2 1100.5 Specifications

Rated Continuous (RMS) Power into 4 Ohms at 14.4V	150 Watts x 4
Rated Continuous (RMS) Power into 2 Ohms at 14.4V	150 Watts x 4
Rated Continuous (RMS) Power into 4 Ohms at 14.4V	500 Watts x 2
Rated Continuous (RMS) Power into 4 Ohms at 14.4V (Subwoofer CH)	275 Watts x 1
Rated Continuous (RMS) Power into 2 Ohms at 14.4V (Subwoofer CH)	500 Watts x 1
Frequency Response	20 Hz to 20 kHz
Frequency Response (Subwoofer Channel)	20 Hz to 230 Hz
Crossover Range - CH1/2 High-Pass	50 Hz to 500 Hz @ 12dB/Octave
Crossover Range - CH1/2 Low-Pass	50 Hz to 500 Hz / 500 Hz to 5 kHz
Crossover Range - CH3/4 High-Pass	50 Hz to 500 Hz @ 12dB/Octave
Crossover Range - SUB Low-Pass	30 Hz to 230 Hz @ 12dB/Octave
Bass Boost (Sub Channel)	0 to 12 dB at 30 to 125 Hz
Remote Level Control Included	Yes
Input Sensitivity - RCA Input	200 mV to 3.5V
Fusing	3 x 30 Amp ATC/ATO
Dimensions	12.42"(L) x 6.268"(W) x 2.086"(H)
Start-Stop Vehicle Compatible	Yes (<8 Volts)

ARC AUDIO WARRANTY

ARC AUDIO warranties all new X2-Series Amplifiers against defects in material and workmanship for a period of ONE (1) YEAR from the original date of purchase. This warranty is not transferable and applies only to the original retail purchaser of the product, when purchased from an authorized ARC AUDIO retailer in good standing. Upon inspection by ARC AUDIO should services be necessary under this warranty for any reason due to manufacture defects ARC AUDIO will, at its sole discretion, repair or replace the defective product with new or similar conditioned product at no charge.

THIS WARRANTY DOES NOT COVER INSTALLATION OR DAMAGE RESULTING FROM AN ACCIDENT, MISUSE, ABUSE, IMPROPER WIRING, OPERATION OUTSIDE OF THE MANUFACTURER'S RECOMMENDATIONS OR SPECIFICATIONS, OR AGAINST INSTRUCTIONS IN THE OWNERS MANUAL.

ARC Audio products contain many delicate circuits and dangerously high voltages can be present even after power has been removed. These products are designed, tested and tuned for proper functionality and there are no user serviceable parts inside. Please Keep Out!

All warranty returns should be sent to ARC AUDIO freight prepaid and must be accompanied by proof of purchase (a copy of the original sales receipt). Direct returns from consumers or non-authorized retailers will be refused unless specifically authorized by ARC AUDIO with a valid Return Authorization number.

All warranty returns should be packed in original packaging and must be accompanied by a copy of the original sales receipt. Product damaged in shipment will not be covered under this warranty. The customer or retailer may choose to have this damage repaired at the normal "Out of Warranty" repair cost.

In no event will ARC AUDIO be liable for incidental, consequential, or other damages resulting from the use or miss-use of this product. This includes but is not limited to, damage of hearing, property or person, damage based upon inconvenience or in loss of use of the product, and to the extent permitted by law, damages for personal injury. This warranty gives you specific legal rights, and you may have other rights, which vary from state to state. This warranty applies to products sold and used in the United States of America. In all other countries please contact your distributor for warranty guidelines and limitations.

ARC Audio
4719 Green Leaf Circle
Modesto, California
95356 USA
209-543-8706